

REEF-PRO AQUARIUMS

Installation Instructions

For all Reef-Pro models



FOLLOW US FOR INSPIRATION!

 [fb.com/theaquariumsolution](https://www.facebook.com/theaquariumsolution)  [fb.com/groups/ddaquapro](https://www.facebook.com/groups/ddaquapro)

— www.theaquariumsolution.com —



D-D Reef-Pro Systemised Aquarium

Please read the following installation instructions carefully before starting to assemble and run your aquarium. If correctly installed, your new aquarium should give you years of pleasure in this fantastic and enthralling hobby.

STEP 1. POSITIONING THE AQUARIUM

Take great care, your Reef-Pro aquarium when filled will be very heavy!

You must establish a suitable position and ensure that the floor or cabinet which you are installing it on is suitable for the weight of the tank, water and substrates without deforming or collapsing.

Reef-Pro cabinets are designed to fully support your aquarium. If the aquarium is not being installed on an Reef-Pro cabinet then care must be taken to ensure the surface is strong enough and is flat and level. Failure to do so may cause the aquarium to crack or the silicone joints to fail over time and may invalidate the warranty.

If you are uncertain that your floor will be strong enough to take the weight of the filled aquarium, or requires support, please take professional advice.

We recommend that any aquarium should be positioned out of direct sunlight and away from a static heat source, such as a radiator.

Approximate system weights

MODEL	CABINET	TANK	SUMP	WATER VOLUME/ WEIGHT	TOTAL	ADJUSTABLE FEET	PEOPLE REQUIRED
REEF-PRO 600	37 KG	39 Kg	20 Kg	170 L / 175 Kg	271 Kg	4	2
REEF-PRO 900	52 Kg	65 Kg	25 Kg	290 L / 297 Kg	462 Kg	4	2
REEF-PRO 1200	68 Kg	79 Kg	25 Kg	365 L / 374 Kg	572 Kg	6	2-4
REEF-PRO 1500S	98 Kg	133 Kg	30 Kg	500 L / 513 Kg	851 Kg	8	4-6
REEF-PRO 1800	115 KG	180 Kg	40 Kg	561 L / 575 Kg	910 Kg	8	6

IMPORTANT: Aquarium care

The Reef-Pro aquarium cabinet is designed as a piece of furniture and although it is water resistant it is NOT WATERPROOF and requires care and attention to prevent damage.

It is important that any water spillage or standing water is wiped up immediately to prevent damage to the board or edging which would not be covered under warranty.

Chemical products should not be used to clean the aquarium or cabinet as they may be toxic to aquatic life.

To avoid scratches when cleaning the glass do not use abrasive materials and take care when using bladed cleaners.

STEP 2 LEVELLING THE CABINET

To ensure long term stability of your aquarium once it is filled, it is of paramount importance that the cabinet and tank are correctly levelled. This ensures that there is no stress on the glass and that the doors will hang square.

Preparation

Ensure that the area where the tank is to be installed is clear so that you have plenty of space for access and adjustment. The cabinet should be initially levelled without the tank and sump installed and we recommend that you remove the quick release doors for better access by pressing the lever at the back of each hinge.

When positioning the tank it is important to have enough people to safely move the aquarium. Jewellery that could potentially scratch the glass or cabinet finish should be removed prior to moving any aquarium or cabinet.

Checking the aquarium on arrival

Transport damage – your aquarium will arrive fully protected and should be carefully unwrapped and checked for any damage.

You must check the aquarium and report any transport damage to your retailer within 12 hours of delivery.

Ensure that there are no missing or damaged parts. Report any issues to your retailer within 24 hours.

IF THERE ARE ANY ISSUES OR CONCERNS THEN DO NOT FILL THE AQUARIUM WITH WATER

Although the tanks are cleaned prior to packing we recommend using a soft sponge and clean water to wipe the inside of the sump and aquarium before setup to remove any residue dust or debris.

The wooden cabinet should ideally be positioned on a level, flat floor. If the floor is not completely level or flat, then it will be necessary to level the cabinet using the adjustable feet.

This is important to avoid warping or movement over time and to ensure that the aquarium is fully supported.

Start by establishing if your floor is level by placing the cabinet roughly in position and using a spirit level on the top of the cabinet.

Equipment: A spirit level of at least 60-90cm in length will be required, the longer the better, a 12mm spanner and 17mm spanner to adjust the feet.

1. Level back to front.

- Cabinet leans backwards - extend all back feet, on larger models adjust middle feet first.
- Cabinet leans forwards - extend all front feet.

2. Level side to side.

- Cabinets with centre feet – if one end is higher than middle, raise both centre feet to match the highest point. Adjust all other corner feet down to firmly touch the floor.
- Cabinets without centre feet – extend feet at lowest end until level.

3. Final cabinet check, adjust if necessary.

- Re-check top of cabinet is level front to back and side to side, at multiple points.
- Re-check all feet are firmly on the floor.

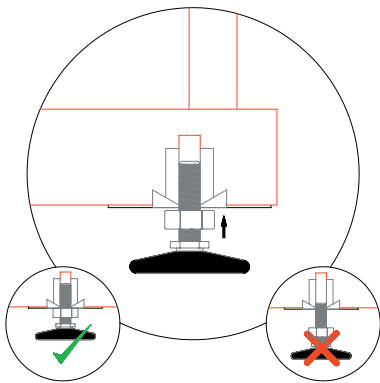

Installing the tank and the sump

The cabinet comes fitted with protective mat for the sump. Do not remove this mat. Install the sump in the cabinet, be careful not to catch the metal hinges with the glass sump when positioning.

Place the aquarium carefully onto the top of the cabinet, ensuring that the protective base mat is sandwiched between cabinet top and tank base. The front corners of the aquarium should line up with the front corners of the cabinet.

After installing the tank and sump, but before filling, check the level again by placing the spirit level along the top edges of the tank and make any fine adjustments. Leave the tank to settle for a couple of hours and then re-check and adjust if necessary.

STEP 3 INSTALLING THE PIPEWORK

The Reef-Pro aquarium pipework is designed to be easy to install using two people, without the need for aquarium silicone or tools. The three pipes can be installed in any order, but the following will allow for the easiest install.

Main overflow pipe

The main weirbox overflow pipe is the shorter of the two 32/40mm diameter pipes.

Ensure that the flexible rubber seal is in place at the top of the threaded section so that it will seal between the pipe and the aquarium glass. Insert the pipe down the weir so that the threaded end goes through the hole.

Take the lower part of the main overflow pipe, which is fitted with a gate valve, ensure the rubber o-ring is in place.

Offer up the female threaded end of the pipe to the male thread coming down through the weir. Whilst one person holds the lower section in place, the other person should turn the upper section in the weirbox clockwise to screw the pipes together until they are hand tight.

Safety overflow pipe

The upper safety overflow pipe is the longer of the two 32/40mm diameter pipes.

Ensure that the flexible rubber seal is in place at the top of the threaded section so that it will seal between the pipe and the aquarium glass. Insert the pipe down the weir so that the threaded end goes through the hole.

Take the lower part of the safety overflow pipe, ensure the rubber o-ring is in place.

Offer up the female threaded end of the pipe to the male thread coming down through the weirbox. Whilst one person holds the lower section in place, the other person should turn the upper section in the weirbox clockwise to screw the pipes together until they are hand tight.

Return pipe

Find the smaller diameter 20/25mm return pipe.

Ensure that the flexible rubber seal is in place at the top of the threaded section so that it will seal between the pipe and the aquarium glass. Insert the pipe down the weir so that the threaded end goes through the hole.

Take the lower part of the return pipe with the hose tail, ensure the rubber o-ring is in place.

Offer up the female threaded end of the pipe to the male thread coming down through the weir. Whilst one person holds the lower section in place, the other person should turn the upper section in the weirbox clockwise to screw the pipes together until they are hand tight.

Upper return pipe: line up the top of the long pipe with the pre-fitted nozzle assembly on the weir.

The two halves of the threaded union should meet and sit flat against each other when the horizontal pipe is level. The height of the upper half of the union can be adjusted by screwing it into the threaded elbow, turning clockwise or anticlockwise to shorten or lengthen the pipe. Screw both parts together with the locking ring. (see image to right)

The pre-assembled pipework fitted through the weirbox, is threaded to make it removable for cleaning.

There is a single outlet pipe and bends, which passes through the front of the weirbox, supplied with a flat fan nozzle and also a **Random Flow Generator** nozzle.

The 1800 model outlet is fitted with 2 nozzles.

For all models there is a small 3mm hole drilled in the pipework, just below the water surface, to act as an anti syphon break and this hole should always be kept clear by regular maintenance.

Lower Return pipe: Push the length of flexible hose on to the hose tail as far as it will go, so that it meets the collar at the top of the barb. Use a plastic pipe clamp or large cable tie to hold in place.

The end of the flexible hose should be positioned in the return pump section of the sump ready for the pump.

Reef-Pro 600/900/1200/1500 Pipework Layout

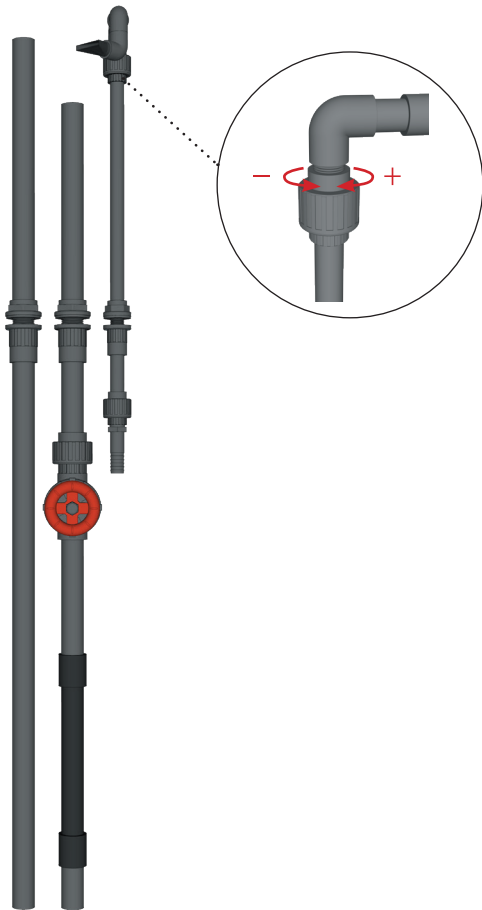

'Invisible' Weirbox

The Reef-Pro models are fitted with an 'Invisible' weirbox and UltraFlow overflow comb to maximise the amount of water that will pass over the weir.

The overcomb section is easily removable for cleaning.

Sump layout and setup

The glass sump is designed to be large enough to accommodate most types of equipment and various methodologies for running a reef aquarium.

All sumps are ClariSea ready so that a ClariSea fleece filter will just drop in and there is a filter sock option which can be specified at the time of ordering.

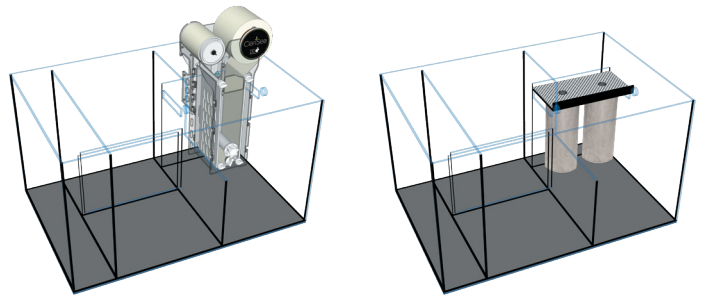

Reef-Pro 1800 Pipework Layout

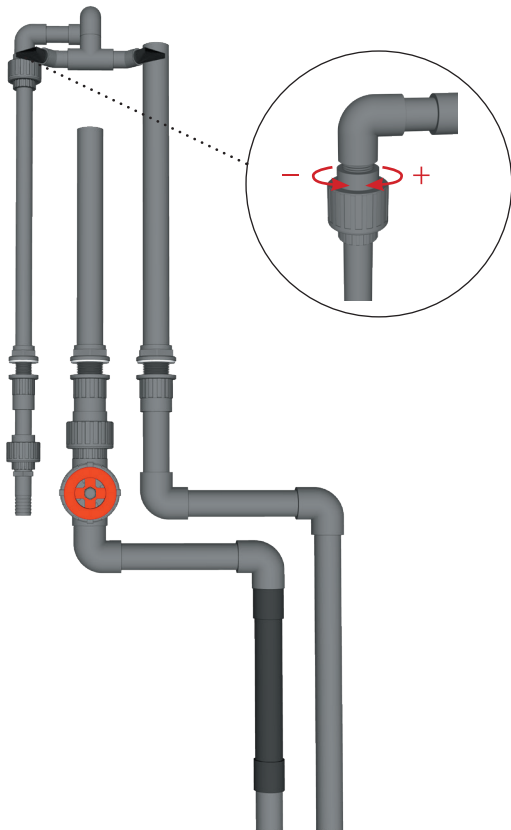

REEF-PRO 600 SUMP LAYOUT

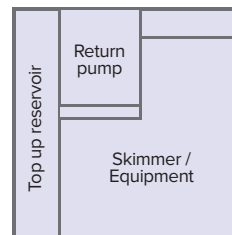

REEF-PRO 900, 1200, 1500 SUMP LAYOUT

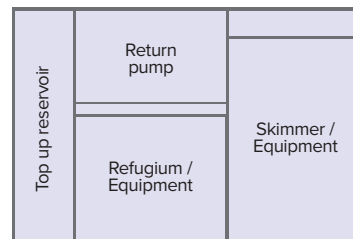

REEF-PRO 1800 SUMP LAYOUT

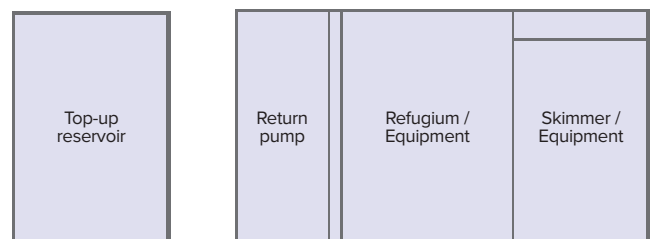

STEP 4. FILLING & TESTING THE AQUARIUM

Initial testing of the pipework

Before filling the aquarium, it is best to test that the pipework and tank connectors do not leak by first closing the gate valve on the main overflow pipe and then filling the overflow box only. Check underneath for any drips or weeping and, if necessary, tighten up any loose connections.

If there are no leaks, fully open the gate valve and continue with the aquarium set up. Be aware that when opening the gate valve, the water used to test the pipe connections will flow from the weir into the sump.

Starting the aquarium and balancing the weir

When starting water circulation through the sump and aquarium for the first time, adjustments will need to be made to the gate valve on the main overflow pipe to ensure quiet running.

Once the return pump has been installed in the sump, fill the aquarium to the level of the bottom of the weir comb and the sump to about $\frac{3}{4}$ full.

Make sure that the gate valve on the main overflow pipe is fully open and that the outlet nozzle(s) are just under the surface of the water and angled slightly downwards.

Turn on the return pump so that water starts pumping from the sump into the main aquarium. The water level in the aquarium will rise and start to flow over into the weir box, this will then fill the weir to the level of the main overflow pipe before water starts to flow back into the first chamber of the sump.

As this happens, the water level in the sump will fall. If the return pump starts to draw in air, add more water to the pump chamber. Only add enough water to keep the pump suitably submerged, do not over fill.

Silent Running

At this stage, the overflow will be quite noisy, this is normal. Once water is circulating around the system and the water levels in the sump and main aquarium are stable you can fine tune the gate valve on the main overflow pipe to achieve quiet running. If you have a flow controllable pump, set your pump to the desired power level before continuing.

Close the gate valve slowly in small increments until you start to see the water level inside the weirbox rise. Allow time for this to stabilise. Keep gradually closing the gate valve until the water reaches the top of the emergency overflow pipe and just starts trickling into it.

These adjustments can take some time to perform, it is sometimes best to make a minor adjustment and wait a few minutes before making the next. If water starts flowing down the emergency pipe too quickly then open the gate valve slightly to allow more water down the main overflow and reduce the water level in the weir. As the weirbox is filling, the sump water level will drop slightly, if needed add more water to cover the pump.

During normal running, the water level in the pump chamber of the sump should be about 1 cm below the height of the final baffle. If it is lower than this then add more water and if it is higher then take some water out of the system

Please be aware that it is common to get a small amount of noise from water running through the pipework when new. As the tank matures, biofilms will form that will dampen some noise. It is also possible that minor adjustments will need to be made to the gate valve over the first few days to achieve quiet running as the tank and return pump stabilise.

Double check the pipework connections for any signs of drips or leaking once the tank is running.

When the gate valve has been set, we recommend that you simulate a power cut to check that the drain down volume will not be too much for the sump to handle. Simply unplug or turn off the return pump, the water level in the aquarium will then drop to the level of the syphon break and the weirbox will drain down level with the top of the main overflow pipe.

The sump should not fill to less than 40mm from the top during this test. Once this is done turn the return pump back on and allow the system to reset. As the tank and weir refill, the tank will run noisily but will quieten again as the weir refills and the system returns to its normal levels.

If the water level in the sump is getting towards the point of overflowing and the main tank has not reached its full drain down level, check that the anti syphon hole is not blocked.

If the sump continues to fill then switch on the return pump quickly to drop the level, check the system and carry out the test again.

Please note that as you add equipment into the sump, the volume they displace can overflow the system and some water may need to be removed.

The weirbox overflow will work at its quietest and optimum performance when the water level is at the top during normal operation, with only a slight trickle going down the emergency overflow. This is a better method than trying to perfectly adjust the gate valve to match the return pump flow.

Top up reservoir

All models of Reef-Pro aquariums come complete with a top up reservoir. The 600 / 900 / 1200 / 1500 models have this built into the main sump, the 1800 comes with a separate standalone reservoir that should be positioned to the side of the main sump.

To automatically refill the sump from the reservoir, an auto top up unit will need to be purchased separately, such as the **D-D H2Ocean Compact ATO**.

STEP 5. ADJUSTING THE CABINET DOORS

The doors are pre-set in the factory before packing but the hinges may need to be adjusted slightly once the aquarium is in its final location. It is best to adjust the cabinet doors at the end of installation when the aquarium is full of water.

The soft-close hinges have three points of adjustment. If necessary, make adjustments until the door(s) are level, with an even gap, and close without any obstruction. The push-openers can also be adjusted by twisting them in or out, by hand.

The hinges can show signs of rust over time if splashed with saltwater or with high humidity. For extra protection silicone grease can be applied to their surface to provide a protective barrier. Rust on the surface of the hinge is not covered by warranty.

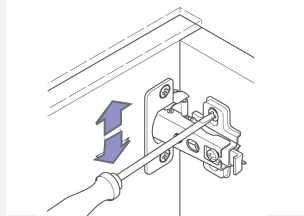

Height

The cabinet doors can be height adjusted marginally with the screws as shown. Loosen the screws on the top and bottom of both hinges and the door will drop down. Lift door into position and tighten screws.

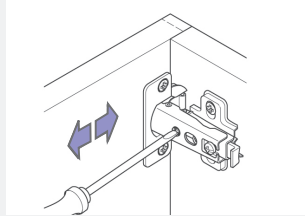

Left to right

Adjustment of the screw as shown will enable left and right alignment of the door. Adjustment of both hinges on the door this way can be used to square it up and will affect the gap between each door when closed.

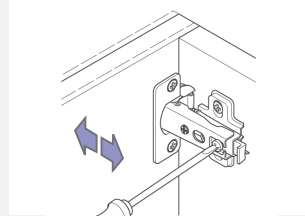

Front to back

The door can be brought forward by loosening the screw as shown. Pull the door out or push it in then tighten screw to fix the position.

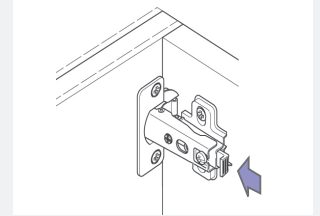

Quick release

The hinges have a quick release mechanism. Push the button at the back of the hinge to release the door, without having to undo the screws.

To compliment and benefit your new aquarium we recommend the following equipment and products...



Prime Flex 18

Prime 16HD



Slimline Bracket Gen 2

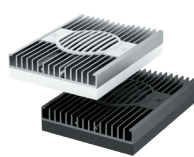

Hydra 32HD

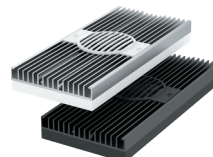

Hydra 64HD



Nero Wave Pumps



RowaPhos Phosphate Remover



Dual Heating and Cooling Controller



AI Blade Lighting



D-D Titanium Heater



DC Series Chillers



ClariSea Fleece Filter



D-D Compact ATO



Deltec Skimmers



FMR75 Fluidised Reactor



H2Ocean Reef Salt

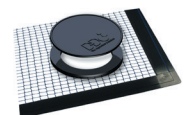

Jumpguard Aquarium Cover

RECOMMENDED EQUIPMENT	REEF-PRO 600	REEF-PRO 900	REEF-PRO 1200	REEF-PRO 1500	REEF-PRO 1800
Return Pump Volume	1500-2000 ltrs/hr	2000-3000 ltrs/hr	3000-4000 ltrs/hr	3000-4000 ltrs/hr	4000-5000 ltrs/hr
Protein Skimmer	Deltec 400	Deltec 400	Deltec 600	Deltec 1000	Deltec 1000
Chiller	DC300	DC300	DC750	DC750	DC750
HYDRA LIGHTING OPTIONS					
Fish Only/Soft Corals/LPS	1 x Prime 16HD	2 x Prime 16HD	3 x Prime 16HD	3 x Prime 16HD	4 x Prime 16HD
Mixed Reef/LPS/SPS	1 x Hydra 32HD	2 x Hydra 32HD	2 x Hydra 32HD	3 x Hydra 32HD	4 x Hydra 32HD
Heavily Stocked SPS	1 x Hydra 64HD	2 x Hydra 32HD	2 x Hydra 64HD	3 x Hydra 64HD	4 x Hydra 64HD
BLADE LIGHTING OPTIONS					
Fish Only/Soft Corals/LPS	2 x Blade 21"	2 x Blade 30"	2 x Blade 39"	2 x Blade 48"	2 x Blade 57"
Mixed Reef/LPS/SPS	3 x Blade 21"	3 x Blade 30"	3 x Blade 39"	3 x Blade 57"	3 x Blade 66"
Heavily Stocked SPS	4 x Blade 21"	4 x Blade 30"	4 x Blade 39"	4 x Blade 57"	4 x Blade 66"

In addition to the above lighting options, it is possible to mix Hydras and Blades for a hybrid solution.